

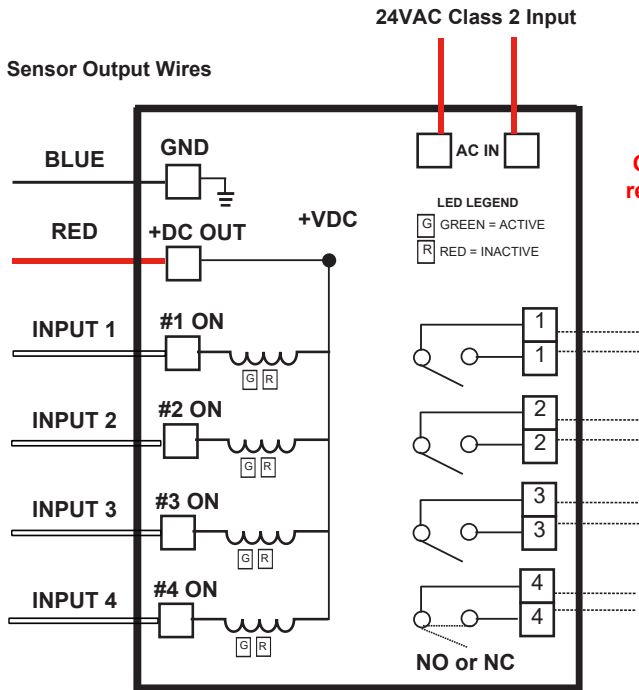

# Checkpoint Mini Control Board MCB-24VAC

System Dynamics, Inc.  
P.O. Box 12544  
Scottsdale, Arizona 85260  
Toll Free: 866-243-2505  
sales@waterlevelcontrols.com  
www.waterlevelcontrols.com

- (3) Normally Open Dry Contact switch outputs
- (1) Optional NO or NC Dry Contact switch output



### Logical View

Outputs 1-4 are Dry Contact relays. Each has a maximum rating of:  
**1A @ 36VDC**  
**0.5A @ 125VAC**

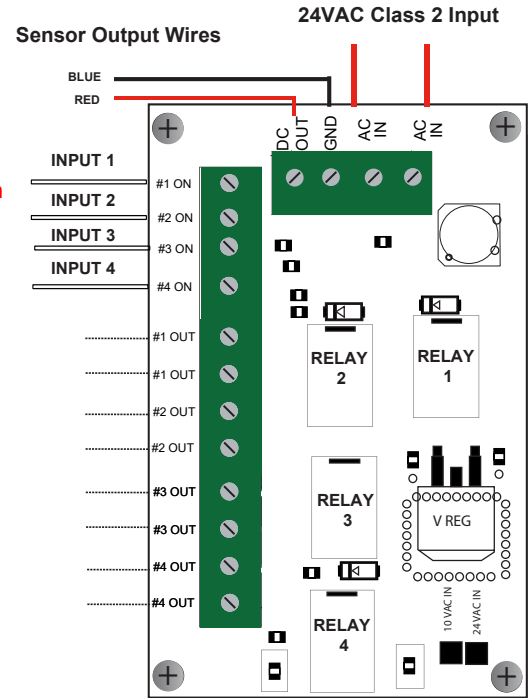

### Physical View

#### NOTE:

The Checkpoint Mini Control Board requires 24VAC Class 2 only input power. The customer can connect their own 24VAC Class 2 power source or purchase one separately. See Add On Options for details and part numbers.

Each Mini Control Board input has a corresponding output.

Inputs 1-3 have Normally Open Dry Contact outputs.

Output 4 has two options:

1. Configured as a secondary output switch (NO or NC) to any of the other switches. See PCB for which resistor to remove for NO or NC output.
2. A Power Loss indicator by connecting DC GND to Input 4 and removing resistor for NC output.

The Load connected to the output should be a 100 - 50k resistive or inductive device (relay coil) drawing 0.0005mA - 250mA.

#### Panel Design Consideration:

Low voltage terminal blocks should be used to connect the Sensor Output wires to the Mini Control Board Inputs. Use matching wire colors between the Sensor Output wires and the Mini Control Board input connections.